

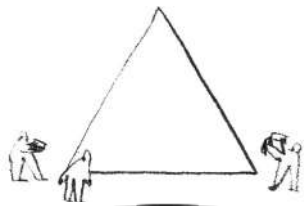

## CHAPTER 2 introduction to sculpture and public art



WHAT IS SCULPTURE?



WHAT IS SCULPTURE?

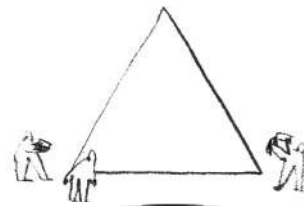
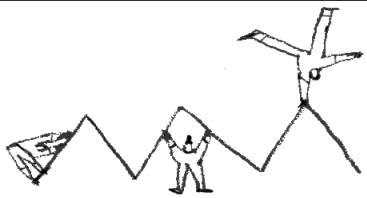

SCULPTURE IS A 3D WORK OF ART  
MADE FROM SOLID MATERIALS LIKE  
STONE AND METAL

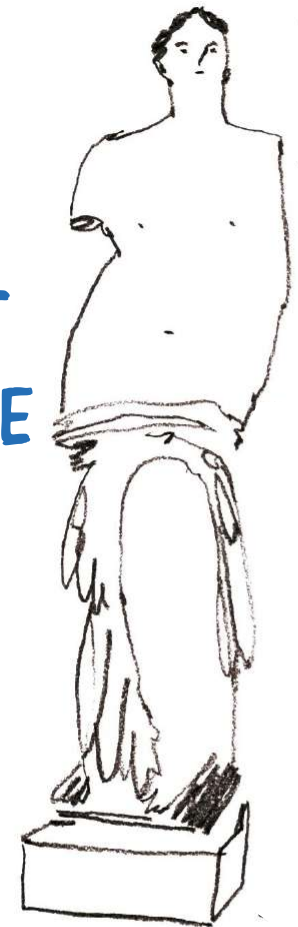

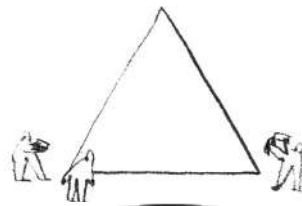

'SCULPTURE' COMES FROM THE  
LATIN WORD 'SCULPO'  
WHICH MEANS 'TO CUT OUT OR TO  
CARVE IN STONE'



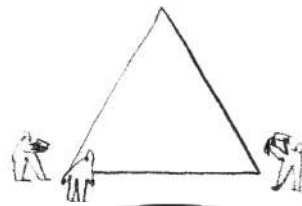
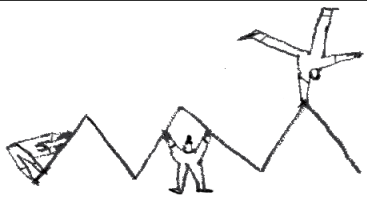

WHAT IS A STATUE?

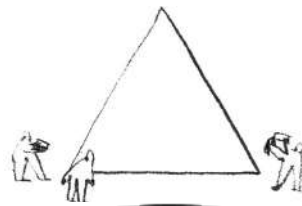

A STATUE OFTEN REPRESENTS  
PEOPLE, ANIMALS, RELIGIOUS  
FIGURES OR MYTHICAL CREATURES!





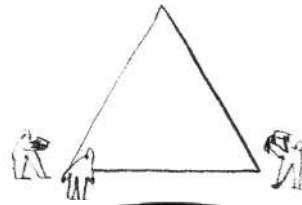
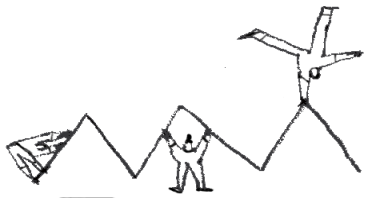

'STATUE' COMES FROM THE LATIN  
WORD 'STATUA'  
WHICH MEANS 'TO STAND'





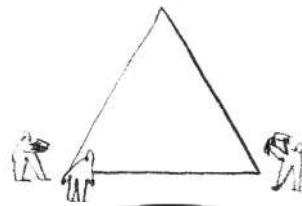
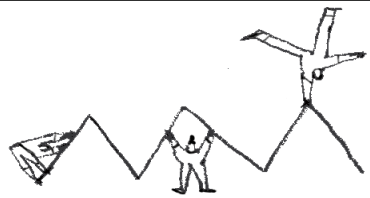

DID YOU THINK SCULPTURE = STATUE?

STATUES ARE A TYPE OF SCULPTURE BUT  
NOT ALL SCULPTURES ARE STATUES!

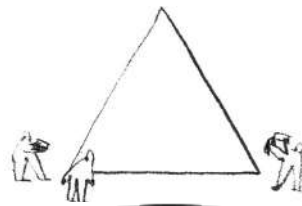
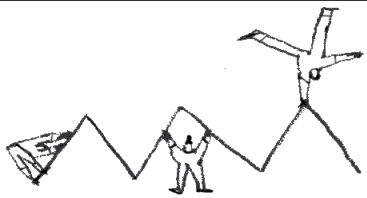

SCULPTURES COME IN DIFFERENT  
SHAPES AND SIZES!

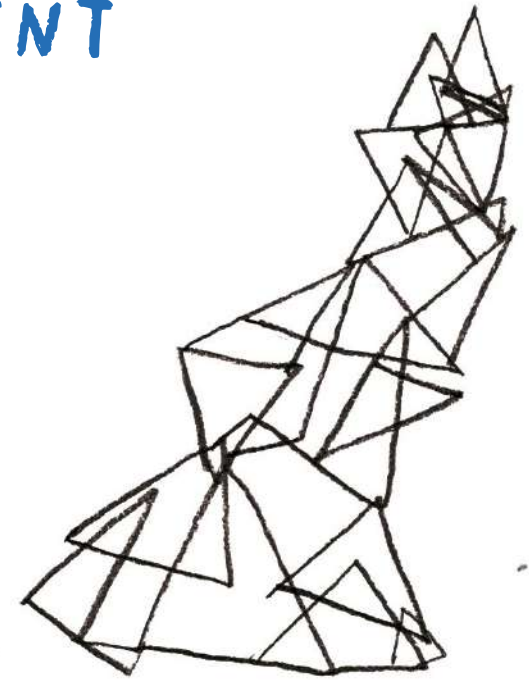

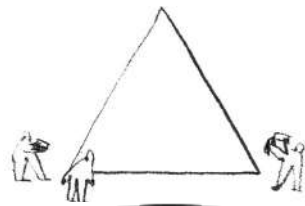

WHAT ARE FIGURATIVE  
SCULPTURES?

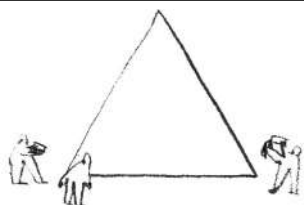
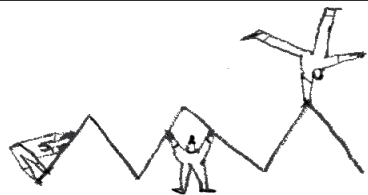

'FIGURATIVE' IS WHEN THE ART  
LOOKS LIKE THE PERSON, ANIMAL  
OR OBJECT THAT IT IS BASED ON  
IN REAL LIFE



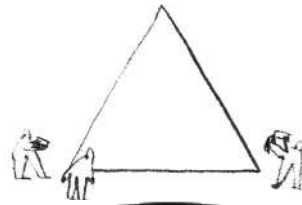
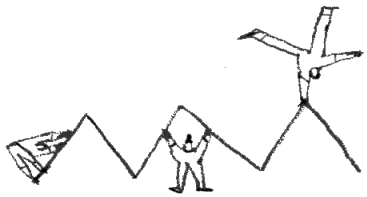

WHAT ARE ABSTRACT  
SCULPTURES?

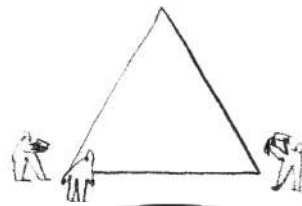
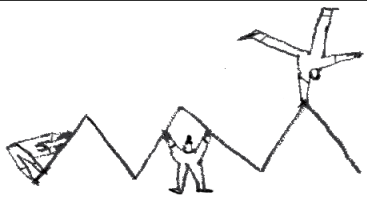

'ABSTRACT' IS WHEN THE ART  
DOES NOT ALWAYS LOOK LIKE  
SOMETHING YOU RECOGNISE IN  
REAL LIFE

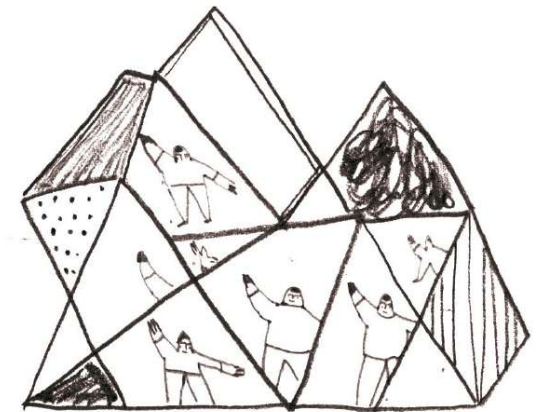
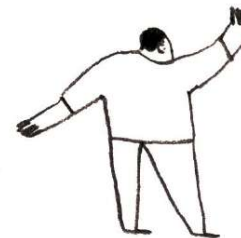

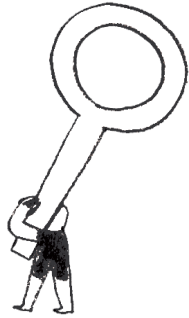

## Key information:

- Sculpture is a 3D work of art made from solid materials e.g. stone and metal.
- Statues are a type of sculpture, but not all sculptures are statues!
- Statues often represent people, animals or mythical creatures.
- Figurative sculptures look similar to the thing it is based on in real life.
- Abstract sculptures do not always look like something you recognise in real life and often uses more unusual shapes, lines and colour.

## SCULPTURE AND STATUE

E.G.



VENUS DI MILO  
ALEXANDROS OF ANTIOCH

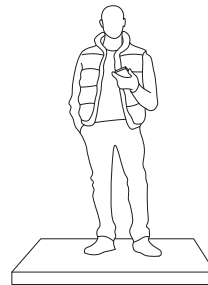

NETWORK  
THOMAS J PRICE

## SCULPTURE

E.G.

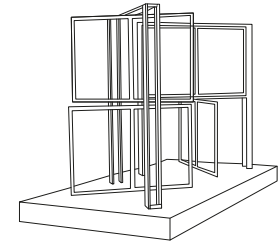

SERIES INDUSTRIAL  
WINDOWS 1  
MARIJA FERRERIA

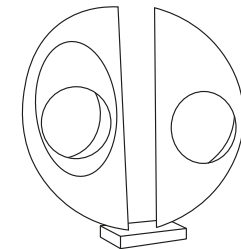

TWO FORMS  
DIVIDED CIRCLE  
BARBARA HEPWORTH



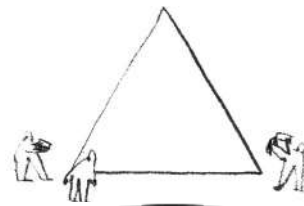
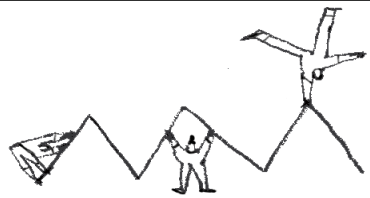

'SCULPTURE IN THE CITY' HAS LOTS OF  
DIFFERENT EXAMPLES OF  
FIGURATIVE AND ABSTRACT SCULPTURES...

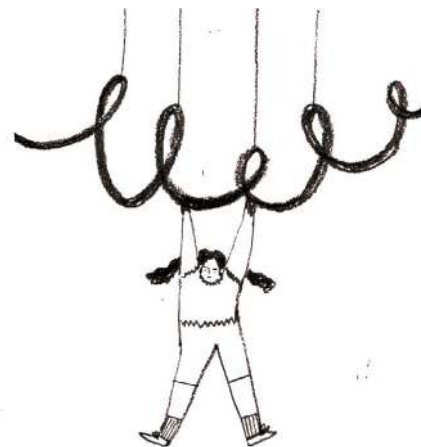

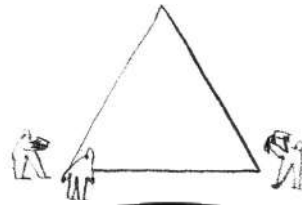
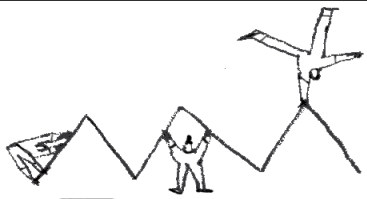

THE 'SCULPTURE IN THE CITY'  
ARTWORK IS LOCATED IN OUTDOOR  
PUBLIC SPACES FOR EVERYONE TO  
EXPERIENCE AND ENJOY!

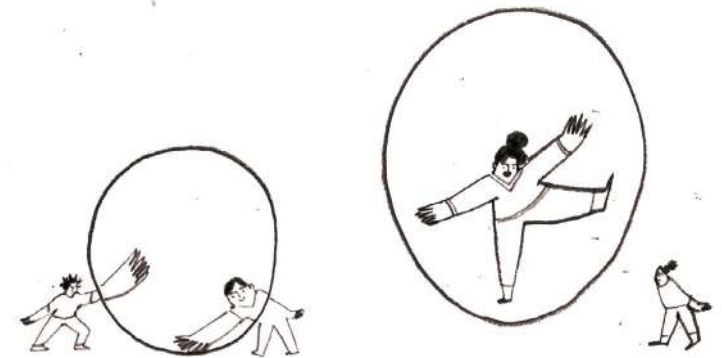

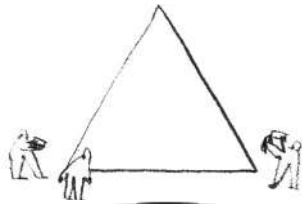
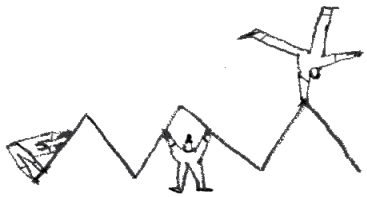

WHY IS PUBLIC ART  
IMPORTANT?

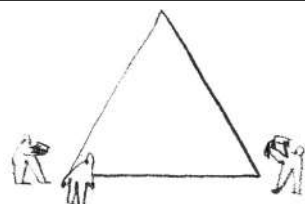
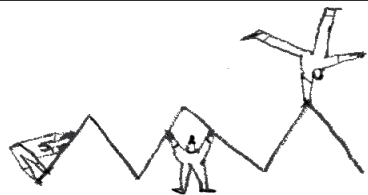

PUBLIC ART CAN CHANGE AND IMPROVE  
PLACES THAT EVERYONE CAN USE.

PUBLIC ART CAN BRING PEOPLE  
TOGETHER, CONNECT US TO OUR  
SURROUNDINGS AND TEACH US ABOUT  
PEOPLE, CULTURES AND HISTORY!

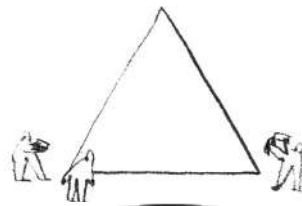

NOW LET'S LOOK AT SOME SCULPTURE  
THROUGH TIME...

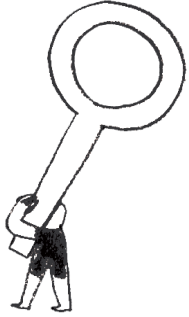

## Key information:

- An ancient Greek statue thought to represent the Goddess of Love.
- Over 2000 years old.
- Material: carved from marble (stone)
- Over 200 years ago, it was found in pieces on a Greek island... the arms were never found!
- Originally would have been brightly coloured with metal jewellery attached.
- Statues of Gods and Goddesses were very important to the Ancient Greeks who worshipped them.



Height = 2.03m

c.150BC

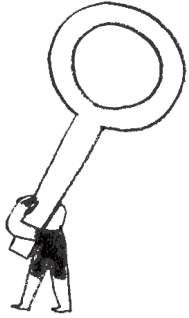

## Key information:

- A representation of the biblical character, David (of David and Goliath)
- Just over 500 years old
- Material: carved from marble (stone)
- The sculpture is a symbol of strength for the Italian city of Florence.
- Created in the Renaissance, a period of time hundreds of years ago starting in Italy when people started wanting to learn more about Ancient Greece and Rome.



Height = 5.17m

1501 - 1504



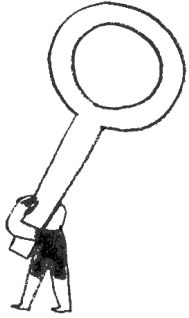

## Key information:

- The artist Henry Moore was revolutionary in the way he created abstract figures. He explored this theme for over 40 years!
- This 'Reclining Figure' is just over 50 years old.
- Material: bronze (metal)
- Moore used abstract forms to make connections between the human body and landscape e.g. mountains and hills.



Length = 3.6m

1969

## SCULPTURE THROUGH TIME

## TWO FORMS (DIVIDED CIRCLE) by BARBARA HEPWORTH

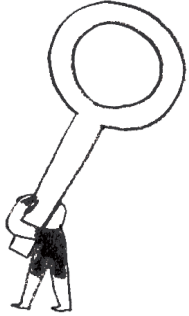

### Key information:

- The artist's sculptures were inspired by landscapes e.g. coastlines and mountains.
- It is just over 50 years old.
- Material: bronze (a metal)
- The holes and gap are as important as the material section.
- The sculpture frames views, so we can see things differently and make connections with the view ahead.



Height = 2.37m

Width = 2.34m

1969





## Key information:

- The sculpture represents the past, the present and the changing times of the region.
- It is just over 20 years old.
- Material: rusted steel (metal)
- It is Britain's largest sculpture.
- It is placed on a hill above an old coal mine, and next to a motorway and railway line.
- The sculpture has become a landmark and symbol for the North East of England.



• 1998

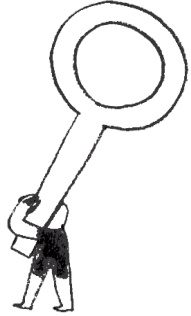

Key information:

- The artist has turned the traditional plinth with a statue on top upside-down!
- It is just over 20 years old.
- Materials: stone and bronze.
- Instead of placing a statue of a famous person on top of the plinth, the artist has placed hundreds of tiny figures underneath it, who are working together to hold up the stone.
- The artist wants us to think differently about who 'heroes' or important people are and how we celebrate them.



Width = 2.75m

Height = 2.84m

• 1998



## Key information:

- Numen means the 'spirit of a place'. The artwork was originally called 'Worship'.
- Completed in 2016
- Materials: marble (stone) and aluminium (metal)
- The artist uses traditional sculpting methods and often represents and celebrates Black people in his work.
- The artist wants us to think more about who in society is given power, and who should be represented in statues and sculpture.



Height = 1.87m

• 2016



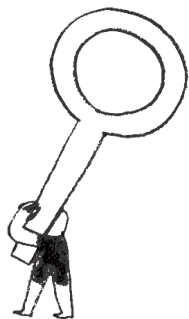

## Key information:

- This sculpture is part of Sculpture in the City's 9th edition!
- Completed in 2017
- Materials: acrylic (plastic), steel (metal) and timber (wood)
- This artwork is brought to life by light! When sunny, the sculpture makes colourful shadows creating a space of moving shapes and colour.
- It's structure is based on early greenhouse designs, where plants grow.
- It was created to mark the 350th anniversary of the Anglo-Dutch wars, and the peace that followed between the countries and the cultural exchanges of growing plants under glass.

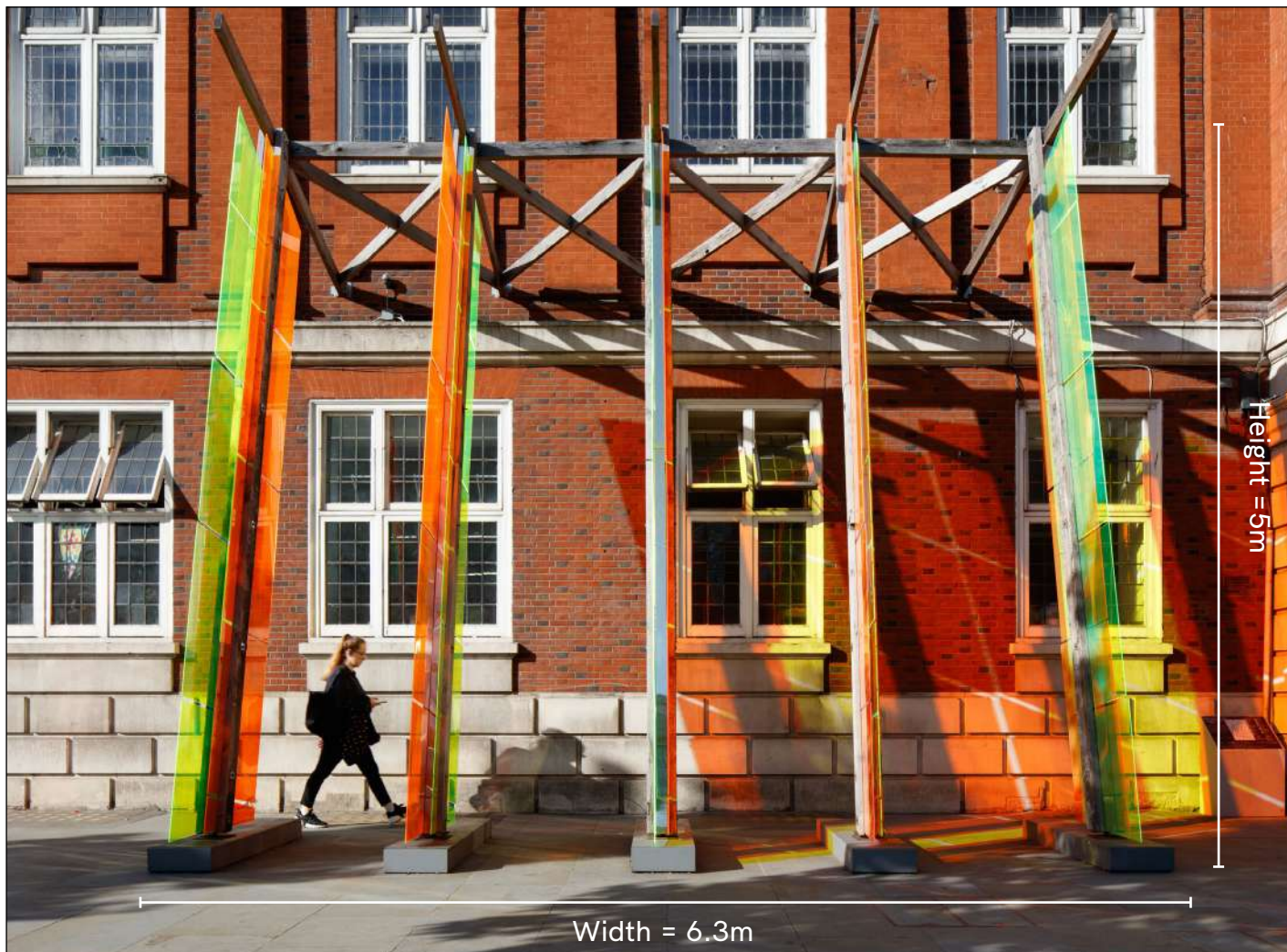

2017

## SCULPTURE THROUGH TIME

## SERIES INDUSTRIAL WINDOWS 1 by MARISA FERREIRA

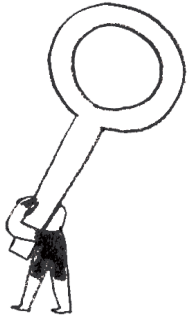

### Key information:

- This sculpture is part of Sculpture in the City's 9th edition!
- Completed in 2018
- Materials: acrylic (plastic) and stainless steel (metal)
- The sculpture explores the artist's memories of the Portuguese city she grew up in.
- The sculpture's measurements are the same size as the windows in a disused factory she played in as a child. The grey frames are made in the same way as a bookshelf found in the factory.
- When sunny the sculpture makes colourful shadows creating a space of moving shapes and colour.



2018



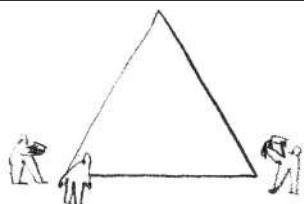
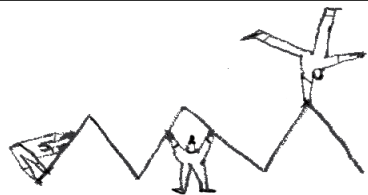

HOW DOES SCULPTURE LINK  
TO ARCHITECTURE?

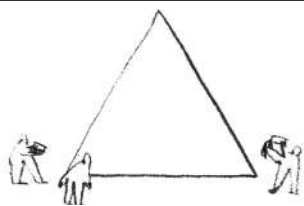
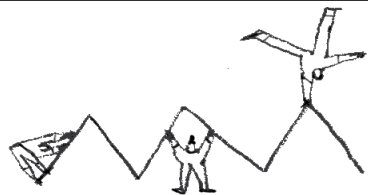

ARCHITECTURE IS THE DESIGNING  
AND MAKING OF BUILDINGS.

LIKE ARCHITECTURE, SCULPTURE CAN  
IMPROVE PLACES, USE STRUCTURES  
AND PLAY WITH DIFFERENT  
MATERIALS

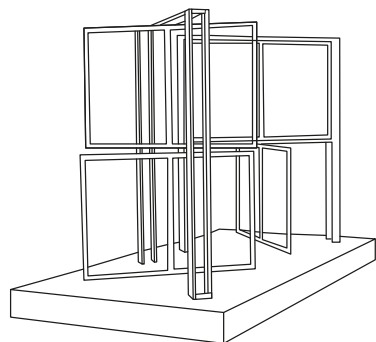

SERIES INDUSTRIAL  
WINDOWS 1  
MARISA FERRERIA

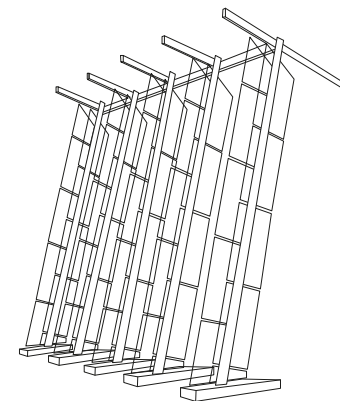

DUTCH LIGHT  
JYLL BRADLEY

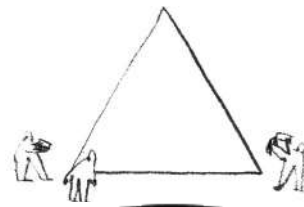
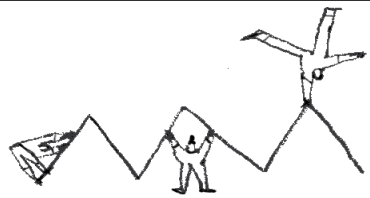

LET'S PLAY A GAME TO INTRODUCE EVEN  
MORE STATUES AND SCULPTURES!

YOU WILL RECOGNISE SOME FROM  
'SCULPTURE THROUGH TIME'

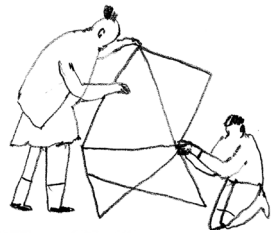

ACTIVITY TIME!

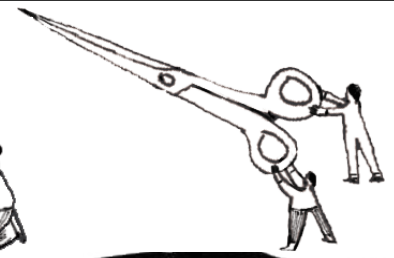
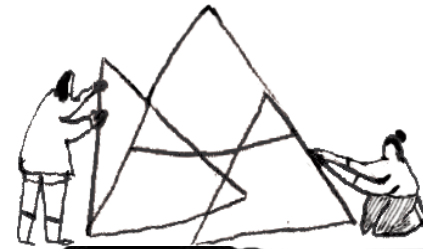

SCULPTURE OR STATUE BINGO!

# ACTIVITY 1: SCULPTURE OR STATUE BINGO

NAME: \_\_\_\_\_



## LEARNING OBJECTIVE:

- To become more familiar with sculpture names and artists including artwork from Sculpture in the City.
- recognise the sculptures that are also statues.

## WHAT YOU NEED:

- Toolkit for Chapter 2 Activity 1
- Scissors
- Pencil/pen (or counters/buttons if available)

KEY:



Cut



Draw

GET THIS SHEET READY!



if you want to play more than one round, instead of crossing out the sculptures use counters, buttons, bottle lids, or even a small piece of scrapped paper etc. to cover them as you play. The calling cards can be reshuffled to play more rounds.

**Step 1:** Cut out the individual caller cards along the dashed lines. One caller per game.

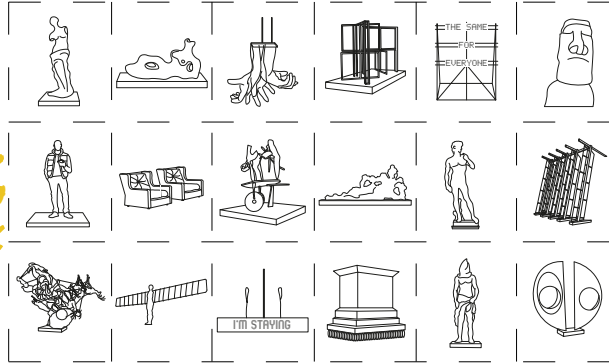

**Step 2:** Cut out the answer cards, one per player/team per round.

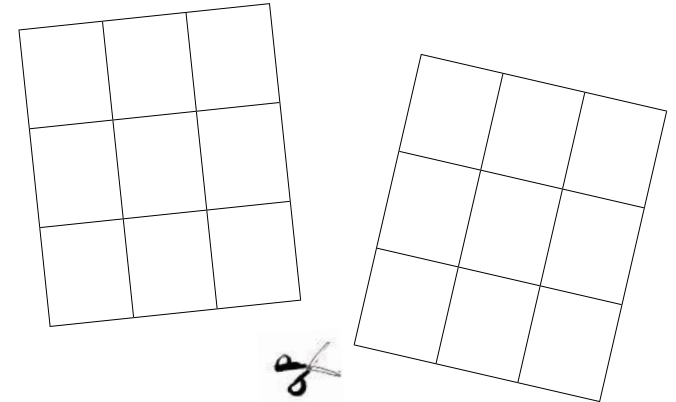

THE TOOLKIT IS NEXT!

**Step 3:** The caller calls out one card at a time.

Dutch Light by Jyll Bradley

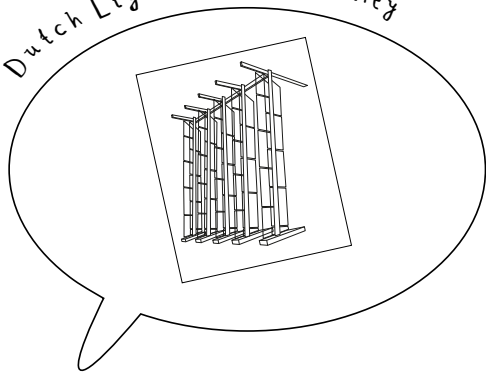

**Step 4:** If the card called out matches what is on an answer card, cross it out.

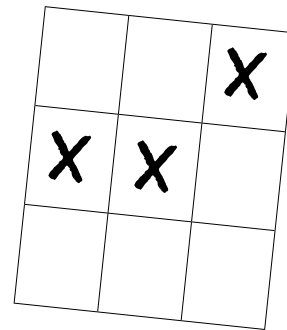
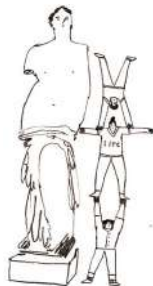

**Step 5:** The game continues until someone crosses out all 9 sculptures on their card and shouts 'bingo!' to win.



# TOOLKIT

## SCULPTURE OR STATUE BINGO: CALLING CARD



### INSTRUCTIONS:

- Cut out the individual cards along the dotted lines
- Follow the instructions on the Activity Sheet

**MORE TOOLKIT NEXT!**



VENUS DI MILO  
ALEXANDROS OF ANTIOCH

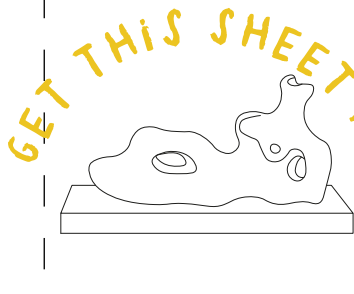

RECLINING FIGURE  
HENRY MOORE

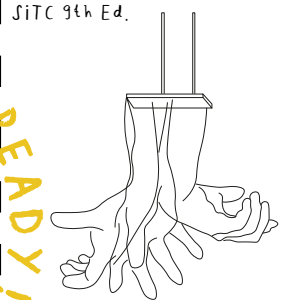

THE SOURCE  
PATRICK TUTTOFUOCO

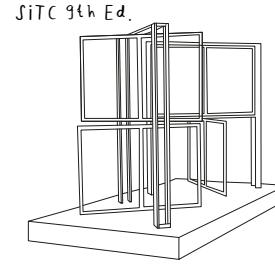

SERIES INDUSTRIAL  
WINDOWS 1  
MARISA FERRERIA

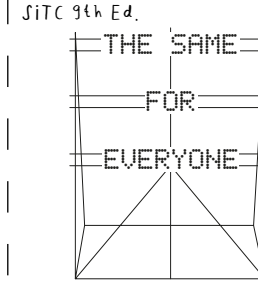

THE SAME FOR EVERYONE  
NATHAN COLEY

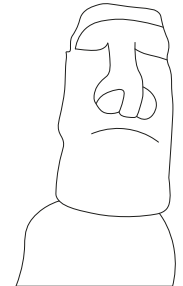

MO'AI  
RAPA NUI

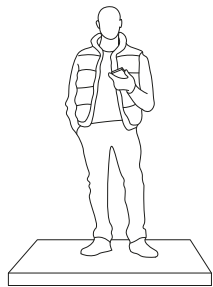

NETWORK  
THOMAS J PRICE

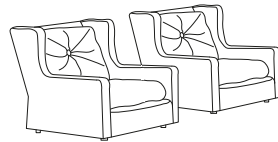

ABSTRACT MASS  
NINA SAUNDERS

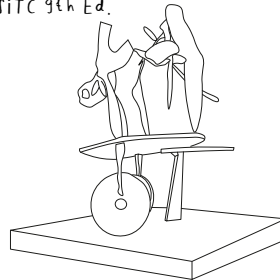

STAGNIGHT  
MICHAEL LYONS

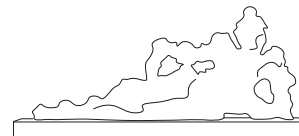

RECLINING NUDE 1  
KEVIN FRANCIS GRAY



DAVID  
MICHAELANGELO

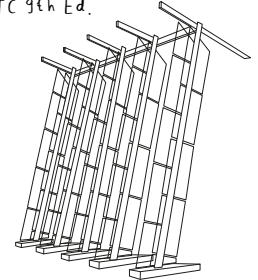

DUTCH LIGHT  
JYLL BRADLEY

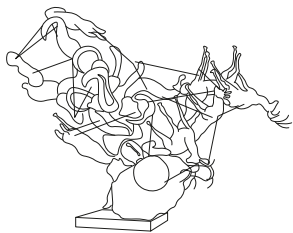

CROCODYLIIS  
PHILODENDRUS  
NANCY RUBINS

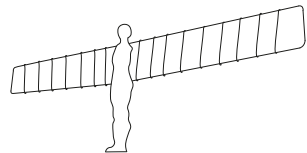

ANGEL OF THE NORTH  
ANTHONY GORMLEY

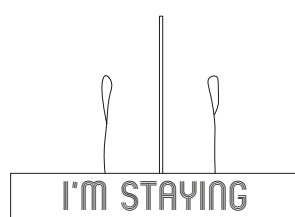

I'M STAYING  
SHAUN C. BADHAM

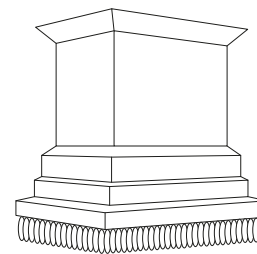

PUBLIC FIGURES  
DO HO SOH

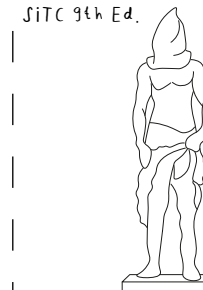

SITE OF THE FALL  
REZA ARAMESH

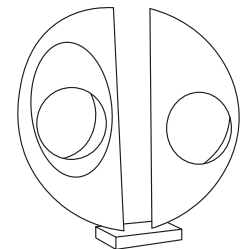

TWO FORMS  
DIVIDED CIRCLE  
BARBARA HEPWORTH

# TOOLKIT

## SCULPTURE OR STATUE BINGO: ANSWER CARDS 1



### INSTRUCTIONS:

- Cut out the template along the outside black square
- Follow the instructions on the Activity Sheet



THE SOURCE  
PATRICK TUTTOFUOCO

MO'AI  
RAPA NUI

CROCODYLUS  
PHILODENDRUS  
NANCY RUBINS

PUBLIC FIGURES  
DO HO SUH

DAVID  
MICHAELANGELO

I'M STAYING  
i'm staying  
SHAUN C. BADHAM

SITE OF THE FALL  
REZA ARAMESH

THE SAME  
FOR  
EVERYONE  
THE SAME FOR EVERYONE  
NATHAN COLEY

NETWORK  
THOMAS J PRICE



SITE OF THE FALL  
REZA ARAMESH

ANGEL OF THE NORTH  
ANTHONY GORMLEY

STAGNANT  
MICHAEL LYONS

DAVID  
MICHAELANGELO

NETWORK  
THOMAS J PRICE

TWO FORMS  
DIVIDED CIRCLE  
BARBARA HEPWORTH

MO'AI  
RAPA NUI

RECLINING NUDE 1  
KEVIN FRANCIS GRAY

SERIES INDUSTRIAL  
WINDOWS 1  
MARISA FERRERIA

GET THIS SHEET READY!

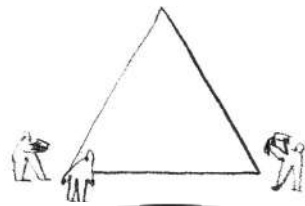
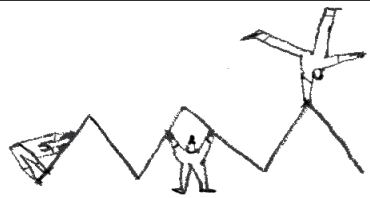

IT'S TIME TO START MAKING  
SOMETHING!



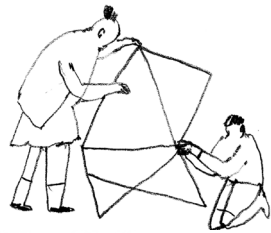

ACTIVITY TIME!

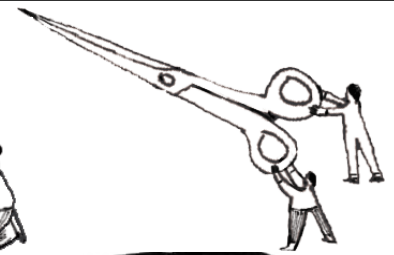
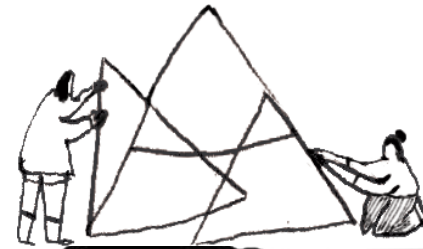

SUNCATCHERS!

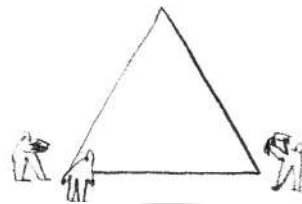
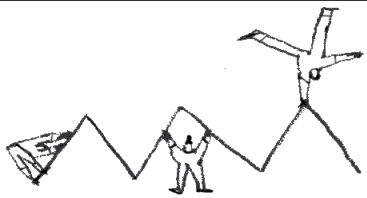

HOW TO MAKE A SUNCATCHER

## ACTIVITY 2: SUNCATCHER



### INSTRUCTIONS

#### KEY:



Stick



Cut



Draw



To cut through the shapes, pinch a small bit of the paper and carefully cut into it. Put your scissors through and cut around.

GET THIS SHEET READY!

#### OBJECTIVE:

- To observe and record the shapes in the sculpture.
- To experiment with and better understand the nature of coloured glass and how it can be used in sculpture.

#### WHAT YOU NEED:

- Toolkit for Chapter 2 Activity 2
- Coloured cellophane/translucent sweet wrappers
- Pencil
- Scissors
- Glue/sellotape

**Step 1:** Look at the shapes in the sculpture. What are the main shapes you can see? Draw them on your sheet and use the example shapes to help. Make sure to only draw in the dashed line rectangle and leave gaps between your shapes!

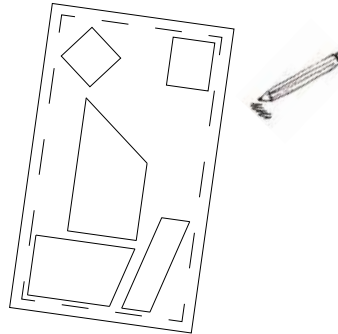

**Step 2:** Cut out the template along the solid black line. Then cut the shapes to leave a stencil for where your coloured cellophane will go.

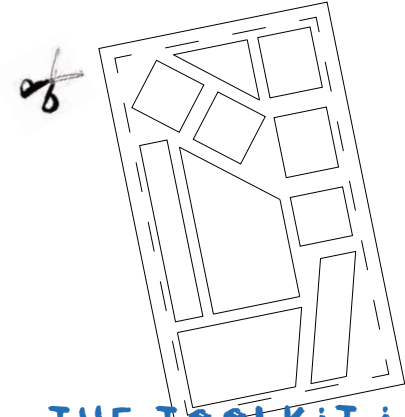

THE TOOLKIT IS NEXT!

**Step 3:** Cut out shapes in different coloured cellophane that are similar to your cut out shapes. Make sure they are big enough to be stuck over the holes.

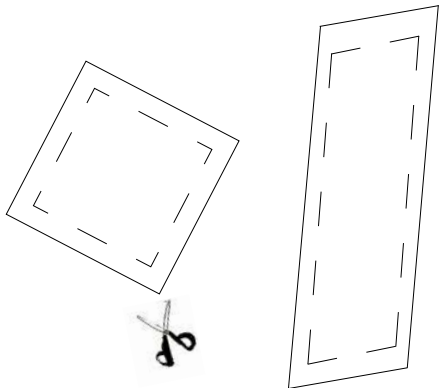

**Step 4:** stick each piece of cellophane over the matching shape/hole on the back of your sheet. Repeat process until all the holes are covered. Turn it over when finished.

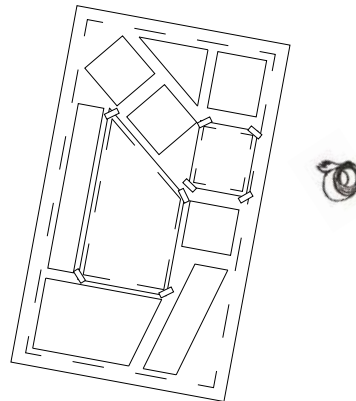

**Step 5:** Rest your 'stained glass' suncatcher on the classroom window sill. Observe the types of shadows they make at different times of the day!

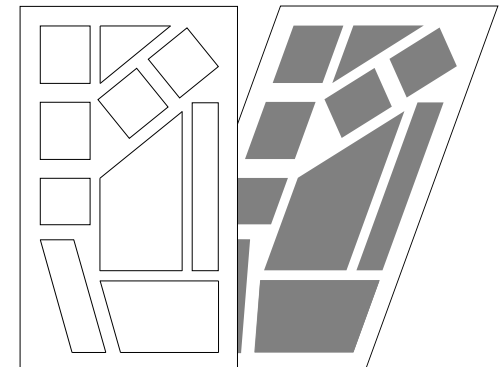

# TOOLKIT

SUNCATCHER: 'STAINED  
GLASS' WINDOW



KEY:



## INSTRUCTIONS:

- Cut out the template along the outside black square
- Follow the instructions on the Activity Sheet



BACK OF TEMPLATE

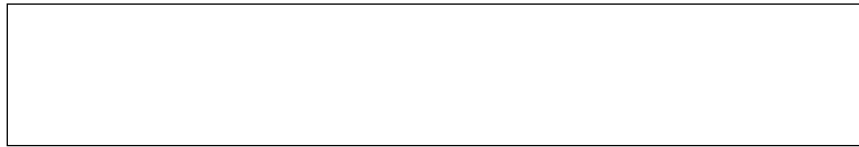
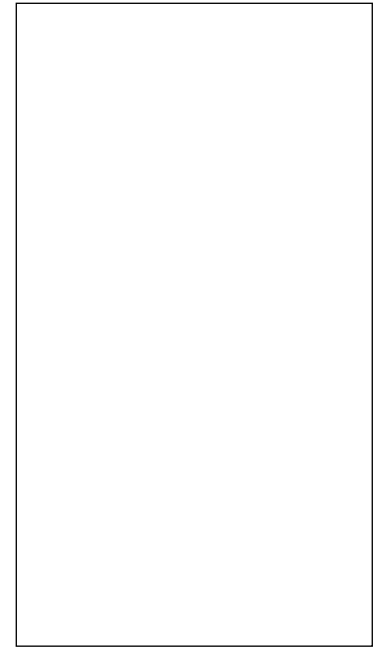
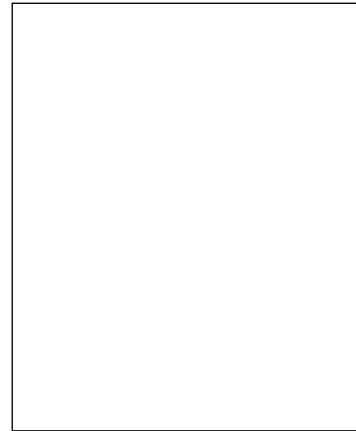
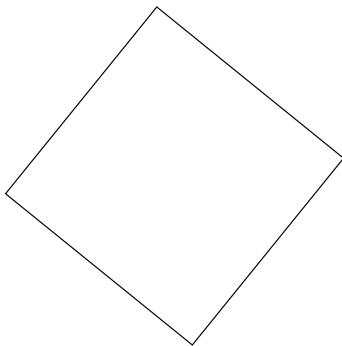
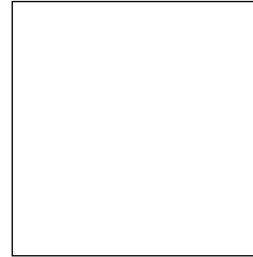
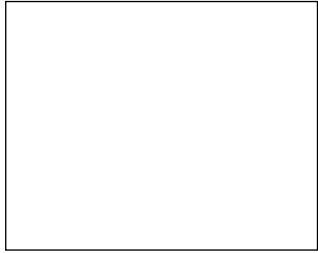

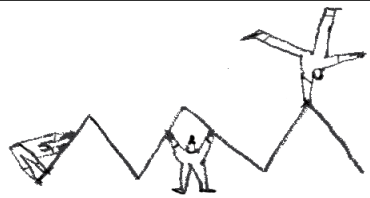

# SERIES INDUSTRIAL WINDOWS 1 by MARISA FERREIRA

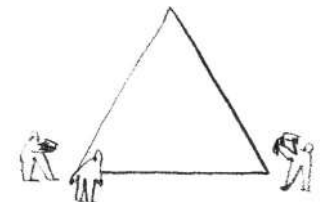

WHAT  
SHAPES CAN  
YOU SEE?



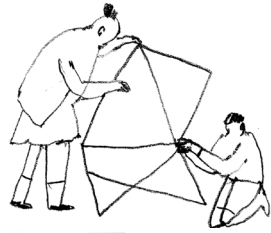

ACTIVITY TIME!  
OR HOMEWORK

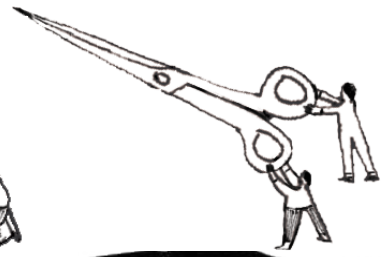
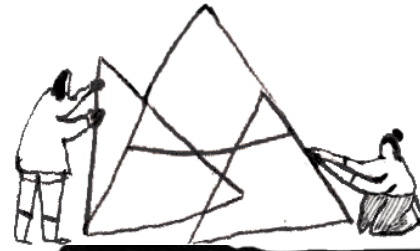

SHADOW MOBILE!

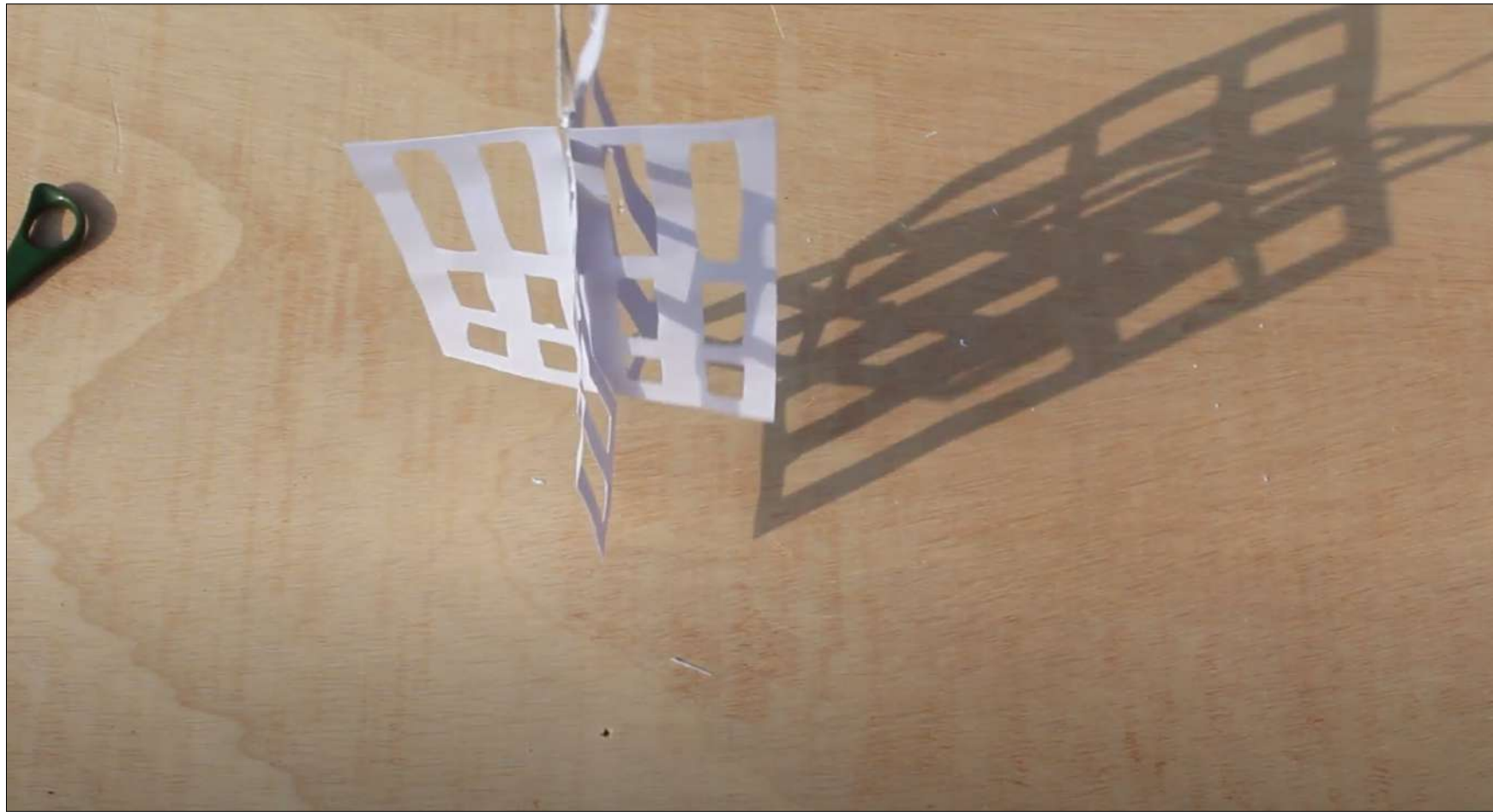
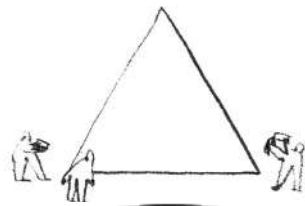
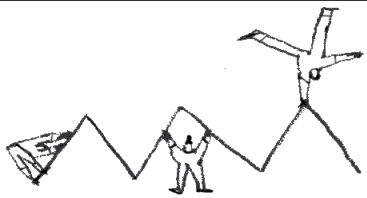

HOW TO MAKE A SHADOW MOBILE

# ACTIVITY 3: SHADOWS



## INSTRUCTIONS

### OBJECTIVE:

- To experiment with and better understand how patterns can create interesting shadows.
- To use card slot joints to create 3D models.

### WHAT YOU NEED:

- Toolkit for Chapter 2 Activity 3
- Scissors
- String
- Glue/sellotape

### KEY:



Stick



Cut

**EXTRA  
ACTIVITY  
OR  
HOMEWORK!**



To cut through the shapes, pinch a small bit of the paper and carefully cut into it. Put your scissors through and cut around.

**Step 1:** Cut out both templates along the solid black lines.

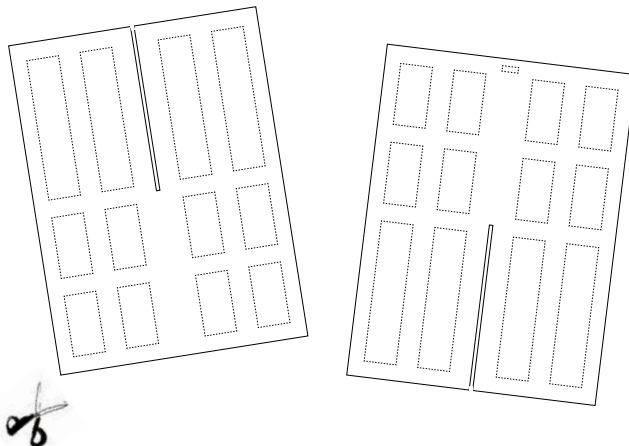

**Step 2:** Cut out the shapes along the dotted line on both templates.

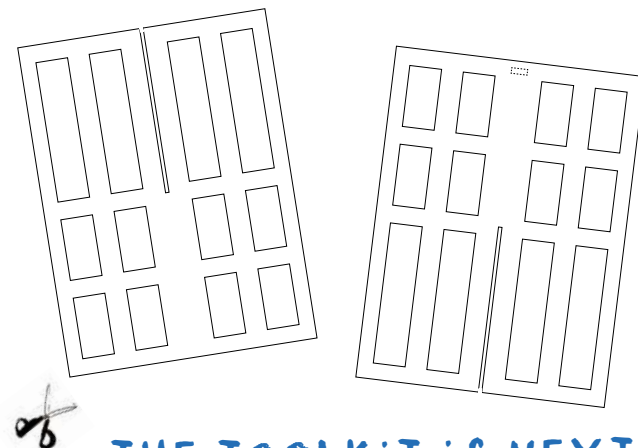

**THE TOOLKIT IS NEXT!**

**Step 3:** slot the two pieces together. Sellotape the two bits together if needed.

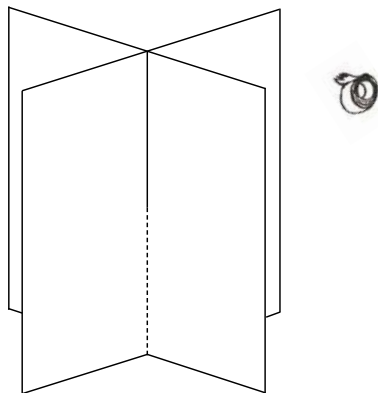

**Step 4:** Tie string through the hole. Make sure the string is long enough to hang up your mobile!

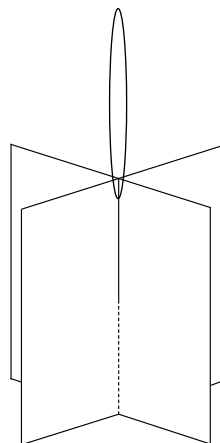

**Step 5:** Hang up by your bedroom window and watch the shadows it makes at different times of the day!

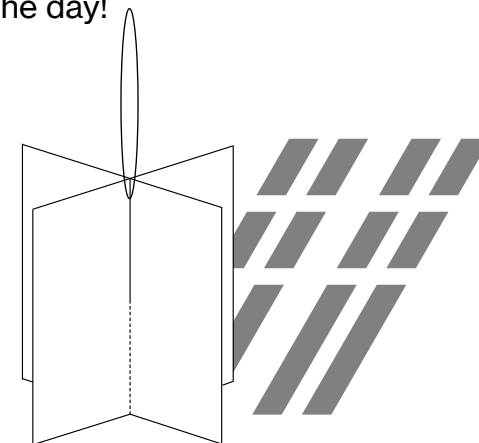

# TOOLKIT

## SHADOWS: MOBILE

KEY:



### INSTRUCTIONS:

- Cut out the template along the outside black square
- Follow the instructions on the Activity Sheet
- Print on thin white card if preferred/available

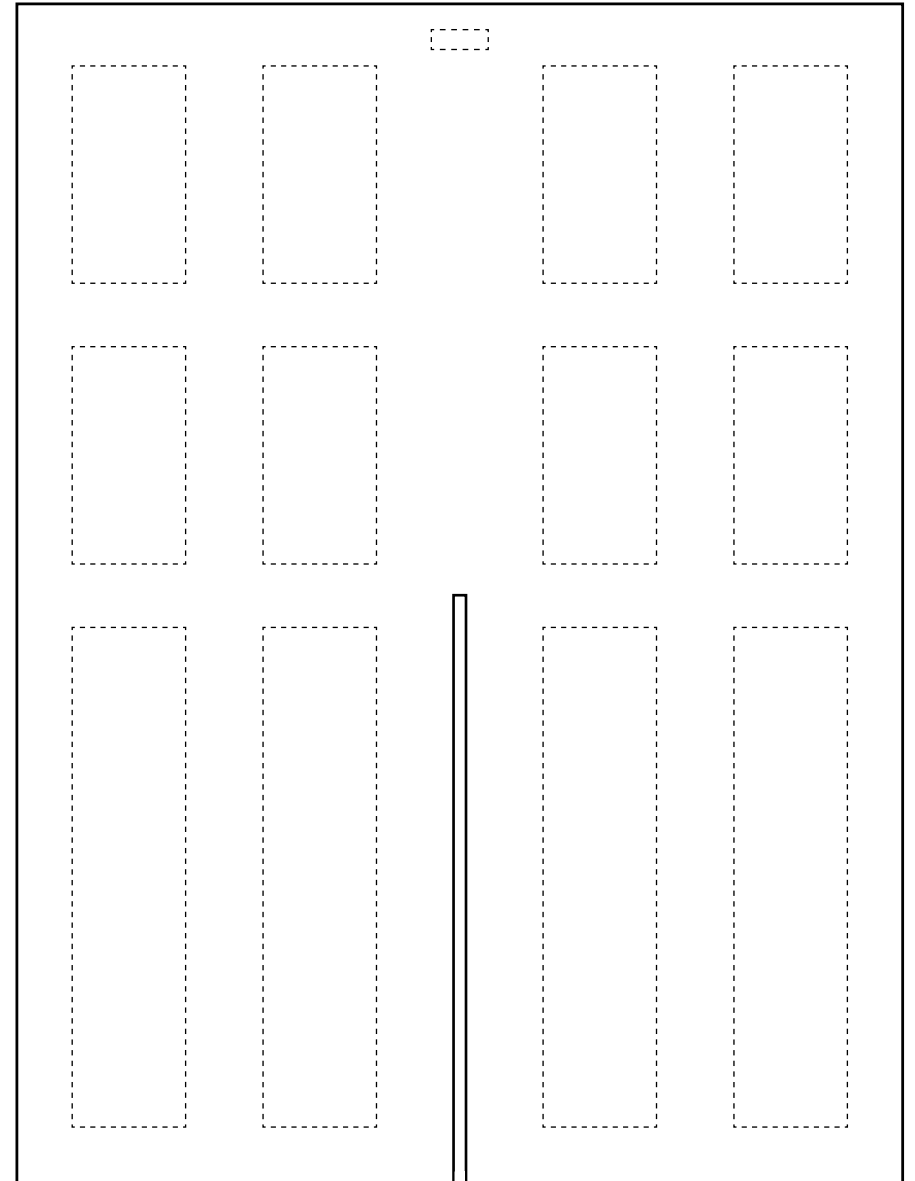
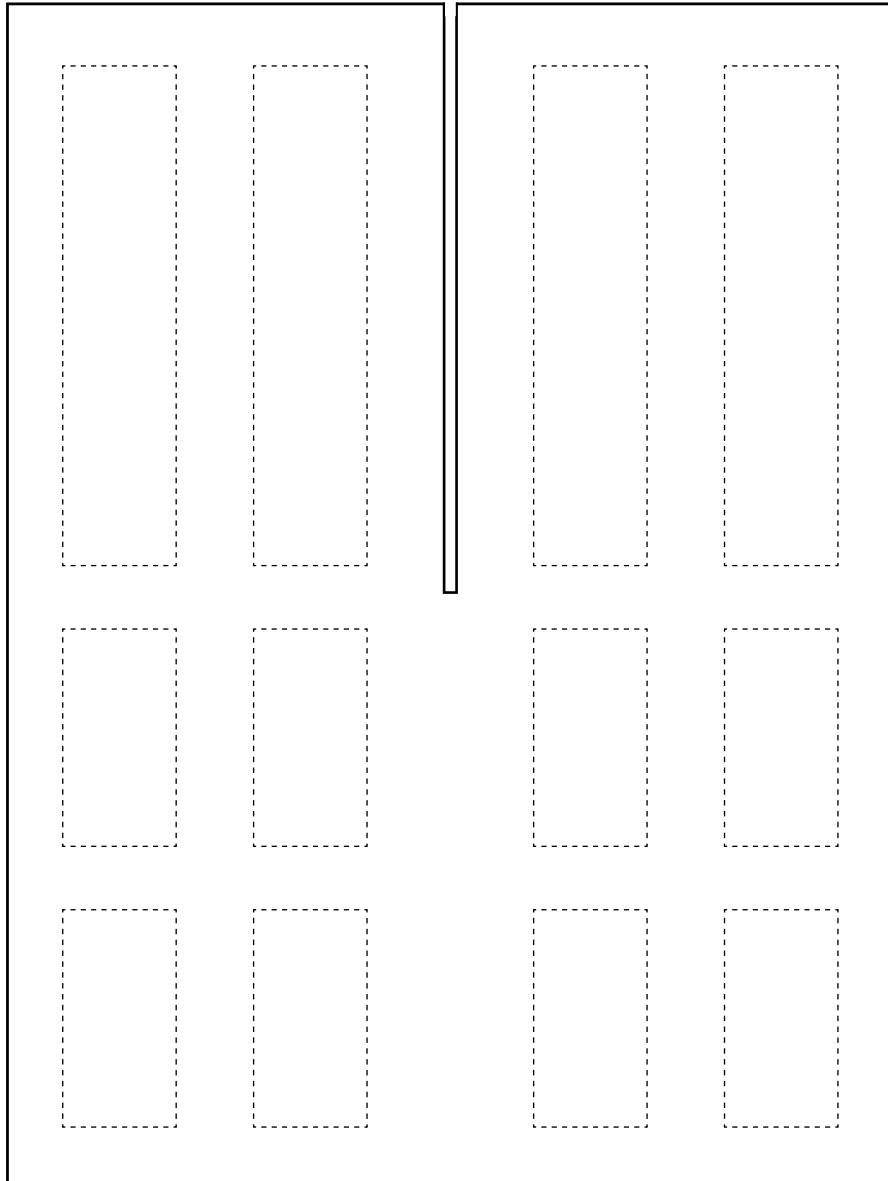

# SCULPTURE IN THE CITY

DIGITAL LEARNING PROGRAMME PARTNER:



PROJECT PARTNER:



# SCULPTURE IN THE CITY LEARNING

DESIGNED BY: **urban learners**

Illustrator: Danielle Rhoda  
Photographer: Luke O'Donovan  
Videographer: CTRL Productions